

Women Safety Band Using IOT

Shweta Suryanwanshi*, Arti Sherkhane**, Archana Sutar***, & Pranjali Gaidhani****

*Assistant Professor Department of E & TC Engineering, DYPIEMR Akurdi, Pune, India

**Department of E & TC Engineering, DYPIEMR Akurdi, Pune, India

***Department of E & TC Engineering, DYPIEMR Akurdi, Pune, India

****Department of E & TC Engineering, DYPIEMR Akurdi, Pune, India

ABSTRACT

In today's world, women's are less secure and having many issues regarding their purpose. They have to many undergo among various difficult situations and have to prove themselves every time in all critical conditions. The paper suggest a new perspective to use for technology for women safety. "Women are Harassed, Raped, and Killed Every Day!!" That's a way beyond HUGE number! We proposed an idea we changes the way everyone things of women safety band. We proposed to have to device which is the integration of multiple devices, hardware comprises of a wearable "Women Security and Safety Smart Band" Which Continuously communication communities with Smart phone that has access to the internet. The application is programmed and loaded with all the required data which includes by using various sensors like temperature sensors, heartbeat sensors and Human behaviour and reactions to different situations like anger, fear. It could be accessed by wireless technologies like GPS, GSM and Wi-Fi modem and monitored by the nearby device. We also have to used Global positioning system (GPS) which will help to detect location of the device. Global System for Mobile Communication (GSM) used in the model is used to send alert message to guardians, relatives and police stations. We have to propose Internet of things (IOT) based device which will help to continuously monitor values of different sensors and Global positioning system (GPS) used in device. In this project System we include wearable devices that will transmit data for comparing with the training dataset and if irregular values in temperature, pulse rate are identified then message will be sent to her family member, nearby police station and one friend.

KEYWORDS: *Microcontroller, Internet of things (IOT), GPS module, GSM, Smart phone.*

INTRODUCTION

In the Women safety device we are using ATmega328 based system. An ATmega328 is one of the series AVR microcontrollers, one of the oldest yet commonly used ATmega328. The implementation of women safety system was done on AVR microcontroller via Global System for Mobile Communication (GSM) modem and interfacing done through MAX-RS 232. In this paper proposed model of a band will provide a required safety of security to women so that they can do late night work. Proposed model contains various sensors which will measure different parameter continuously. Communication of alarming situation and prevention of incident has achieved by Global positioning system (GPS), Global system for mobile communication (GSM) technology. This is the aim of our system.

The Smart Band Integrated with smart phone has an advantages so as reduce the cost of the device and also reduce the size. The women wearing band when finds that someone going to harass, she process the switch button that is located on band, which is accompanied by condition check by temperature and heartbeat sensor. The AVR microcontroller in which contacts four(4) People and message “HELP” stored in memory is sent to destination through Global system for mobile communication (GSM). In panic, women is not able to shout out, this device can easily indicate about dangerous situation to people surrounding by. For self-defence this device includes shock generators which can be women used again an attacker in case emergency. This shock is intense enough to scare the attacker away.

GSM attached to ATmega328 will send message to contact stored in SIM. GPS attached to ATmega328 will track the position of the device. To develop a system for using IOT by android users for keeping track through several applications. This applications users GPS for identifying the location of the person in trouble and the system can be divided into two module.

- 1) First module can be victim’s phone that is the root device which users 2G/3G data connection for tracking the location of the victim through GPS.
- 2) Second module can be the mobile phone of registered contact either police, friends or family members which receivers the message containing URL of the location of victim that is sent from the root device.

i. **Sensing Unit :**

The women safety device senses the emergency situation with help of the sensing unit that consists three elements:

1) Heartbeat Sensor:

The heartbeat sensor is based on the principle of phlethysmography. The flow of blood volume is decided by the rate of heart pulses and since light is absorbed by blood, the signal pulses are equivalent to the heart pulses.

Heart beat can be measured based on optical power variation as light is scattered or absorbed during is path through the glow as the heart beat changes.

2) Temperature Sensor:

This sensor keeps a track of women’s the body temperature and sends the generated analog data to controller.

3) Panic Button:

It’s simple Dual Port Double Throw (DPDT) switch that the women presses when she is an emergency situation and need help.

ii. **Power Supply :**

5V supply is used for Microcontroller, GSM and GPS module while 3.3V power supply is used for various sensors, sensor will continuously send will their values to ATmega328. ATmega328 will compare readings of sensor with threshold value. ATmega328 will generate the “HELP” message accordingly. GPS attach to ATmega328 will track the position of the device. GSM attach ATmega328 will send the message to contacts stored in SIM.

iii. Controller Unit:

ATmega328 is an 8-bit high performance of Atmel Mega AVR family with low power consumption. ATmega328 is based on enhanced RISC architecture 130 powerful. ATmega328 can work on a maximum frequency 16MHz.

iv. Location Tracking Unit:

Current location of woman is fetched by this unit with help of GPS module. GPS module comes ceramic antenna which makes it small and complete solution for enabling GPS to various embedded device module comes standard 2mm DIP pin headers which is easy to interfacing your device.

v. Cellular Messaging Unit:

Location with women along with an emergency Short Message Service (SMS) is sent to police and relatives GSM module. GSM/GPRS module is used to establish communication between computer and GSM system. GSM is an architecture used for mobile communication in most countries. GSM/GPRS module consists of GSM/GPRS modem assembled together with power supply and communication interface for computer.

It can be observed by users, User 1 should have PC or mobile phone for observing through Browser. They should require a domain name through which they will get the current location it can be done by client and server in this client will be ATmega328. Information exchange between client and server is known as IOT.

We can have 'n' number of users. If we want to see long on google earth we will take user2 they will laptop or PC having python code after running it we will get the all the information on google earth.

I. LITERATURE SURVEY :

1) "Smart Security Solution for Women Based on Internet of Things (IOT)"

This paper focused on the security of women. They are build one smart band which is contains three sensors that is temperature sensor, pulse rate sensor and unusually motion detected by the motion sensor. This smart of security band is continuously communicate with smart phone. The system can be perform the real time monitoring of desired area and detect the violence of good accuracy. This an advance system which can detect the location and health condition of person that will enable us to take action accordingly based on electronic gadgets like our sensors. In which we are using concept of IOT so it can detect real time situation of women in critical situation. This idea is completely safe and comfortable and easy to use.

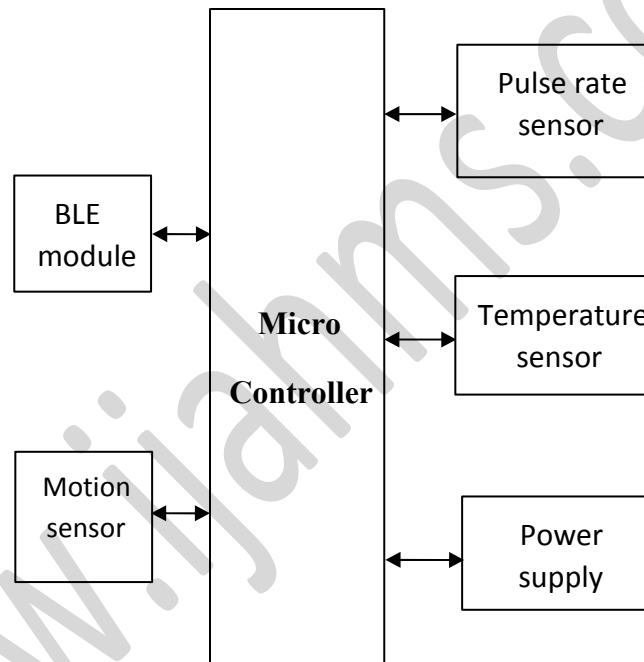
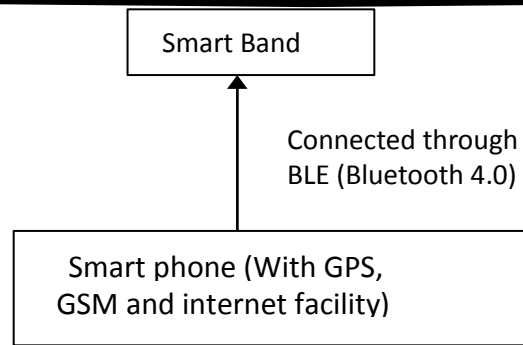

Figure 2: block diag

Figure 1: Main block Diagram

2) “Smart Security girls system”.

This paper focuses on a security system that is designed solely to serve the purpose security women to that they never feel helpless while facing such social challenges. In this paper they gives information about various module like GSM shield (SIM900A), Atmega328 board, Arduino Board, GPS(GYGPS6MV2) tracking, Screaming alarm (ADR 9600), a set of pressure sensor for activation and power supply unit.

- 3) “An Autonomous Wireless Body area Network Implementation towards the internet of Things (IOT) connected Healthcare Application”

This paper describes about wearable sensor nodes with the solar energy harvesting. This paper contain information about various sensor which are used for the monitoring of health condition of person. Also they are developed one web based smartphone application to display the sensor’s node data.

- 4) “A Survey on Wearable sensor based system for health monitoring and prognosis”

In this paper they are build one wearable health monitoring system which is useful to checking the health condition of patients. In this paper they gives information about sensors and working range of sensors and Bluetooth.

- 5) “Android Application for women security system.”

In this paper shows that they are developed one android application which is useful as women security

Purpose. Generally this service can be start by clicking the ACTIVATON SERVICE BUTTON .By pressing VOLUME KEY emergency message will be send to the registered contacts.

- 6) “Design And Development of the Women security and Defence Smart watch Prototype.”

This paper purposes idea of interaction between user and technology. They are developed one Smart Watch which communicate with GPS system. Also they are develop one system which contain electric shock generator module, screaming alarm module, voice recognition module which is useful for women security.

This paper focused on the security of women. They are build one smart band which is contains three sensors that is temperature sensor, pulse rate sensor and unusually motion detected by the motion sensor. This smart of security band is continuously communicate with smart phone. The system can be perform the real time monitoring of desired area and detect the violence of good accuracy. This an advance system which can detect the location and health condition of person that will enable us to take action accordingly based on electronic gadgets like our sensors. In which we are using concept of IOT so it can detect real time situation of women in critical situation. This idea is completely safe and comfortable and easy to use.

- 7) “Smart Security girls system”.

This paper focuses on a security system that is designed solely to serve the purpose security women to that they never feel helpless while facing such social challenges. In this paper they gives information about various module like GSM shield (SIM900A), Atmega328 board, Arduino Board, GPS(GYGPS6MV2) tracking, Screaming alarm (ADR 9600), a set of pressure sensor for activation and power supply unit.

II. CONCLUSION

In our system we developed one women self-security smart band which contain temperature sensor, heartbeat sensor and panic button. In this systems, sensors are continuously communicate

with smartphone by using GSM and GPS modem. It send emergency message automatically to the relatives, friends and nearby police station. Our system is more efficient than other systems.

III. ACKNOWLEDGEMENT

We are thankful to our college Dr. D. Y. Patil Institute of Engineering Management and Research who provided expertized that greatly assisted the research. We are also grateful to Prof. Priya Charles for assistance. We would like to extend my sincere gratitude and thanks to our guide Prof. Shweta Suryawanshi, for her invaluable guidance and for giving us useful inputs, which inspired us to work smarter and hardwork.

IV. REFERENCE

1. G C Harikiran, Karthik Menasinkai and Suhas Shirol, Smart Security Solution For Women Based On Internet Of Things (IOT)", International Conference on Electrical, Electronics, and Optimization Techniques (ICEEOT) – 2016IEEE.
2. Taiyang wu, Fan wu, Jean-Michel Redoute, "An Autonomous Wireless Body area Network Implementation towards IOT connected Healthcare Application", 2016.
3. Alexandrous Plantelopoulous and Nikolaos.G.Bourbakis,"A Survey on Wearable sensor based system for health monitoring and prognosis", Vol.40, No.1, January 2010.
4. B.Chougula, "Smart girls security system",International Journal of Application or Innovation in Engineering and Management Volume 3, Issue 4, April 2014 .
5. Vamil B. Sangoi, "Smart security solutions," International Journal of Current Engineering and Technology, Vol.4, No.5, Oct-2014.
6. Kavita Sharma, Anand More, "Android Application for women security system", International Journal of Advanced Research in Computer Engineering & Technology (IJARCET) Volume 5 Issue 3, March 2016